

Jardine
HEADERS

Slip-on Mufflers
(4 into 2) To fit;

HONDA

When installing JARDINE Slip-on Mufflers, it is very important that the stock pipes are cut off at the correct length.

Check page for your model of HONDA. Measure and mark pipes as illustrated.

Remove nuts (1) collars (2) inserts (3) or clamps at exhaust ports at cylinder head.

Remove the bolts that attach passenger peg and mufflers at rear frame mount. Remove exhaust system.

Use a hacksaw to cut exhaust pipes at mark.

Replace exhaust pipes in cylinder head. Push pipes fully home. Replace inserts (3) collars (2) nuts (1) or clamps. Tighten just enough to hold pipes loosely in place.

ALL CB's UP TO and INCLUDING 1976, Slip on JARDINE Mufflers. Align hole in muffler mounting bracket with the hole in the rear frame mount (muffler bracket

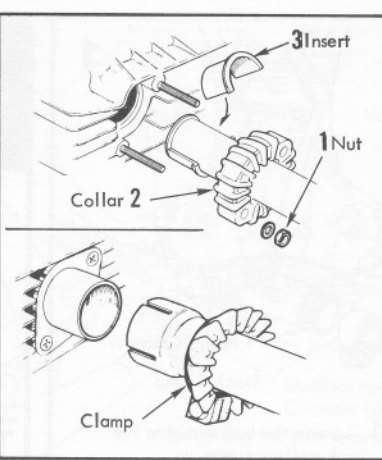

goes inside frame). Replace passenger peg, use stock nut/bolt. Tighten.

ALL 1977 "K" MODELS

A strap is included for use on all 1977 "K" models. This strap is used between the muffler bracket and the rear frame mount.

Attach strap to muffler, using the short nut/bolt/washer supplied. Use the long bolt/nut/washer to attach strap and passenger peg to rear frame mount. Strap goes on inside of frame. Tighten.

Go back and fully tighten the nuts (1) or clamps left loose in STEP 3.

That's it! To protect the chrome finish of the JARDINE slip-on, we recommend the use of a quality, liquid type polish...weekly.

► **IMPORTANT:** Before riding, check that rear brake pedal clears exhaust system. If not, tighten up adjustment on rear brake till pedal clears.

CB350 No's. 1350 Bell
1355 Turnout

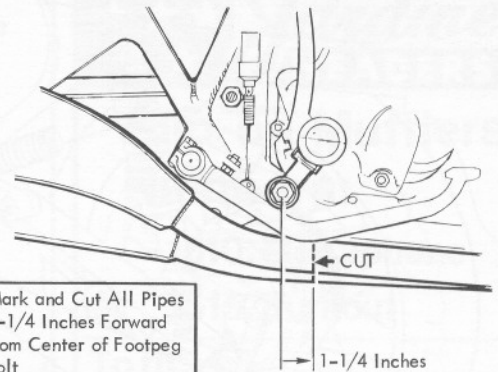

Mark and Cut All Pipes
1-1/4 Inches Forward
from Center of Footpeg
Bolt

CB 500/550
(UP TO AND INCLUDING 1976) No's. 1550 Bell
1555 Turnout
(1977 AND ON "K" MODELS) No's. 1560 Bell
1565 Turnout

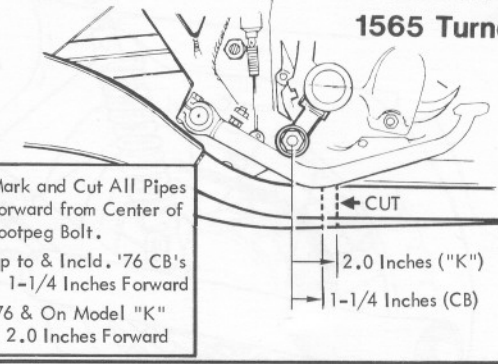

Mark and Cut All Pipes
Forward from Center of
Footpeg Bolt.
Up to & Includ. '76 CB's
1-1/4 Inches Forward
'76 & On Model "K"
2.0 Inches Forward

CB750 No's. 1750A Bell
1765 Turnout
(UP TO AND INCLUDING 1976)

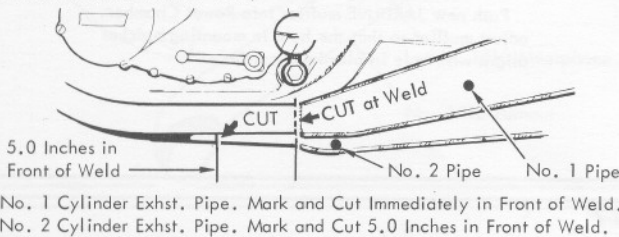

No. 1 Cylinder Exhst. Pipe. Mark and Cut Immediately in Front of Weld.
No. 2 Cylinder Exhst. Pipe. Mark and Cut 5.0 Inches in Front of Weld.

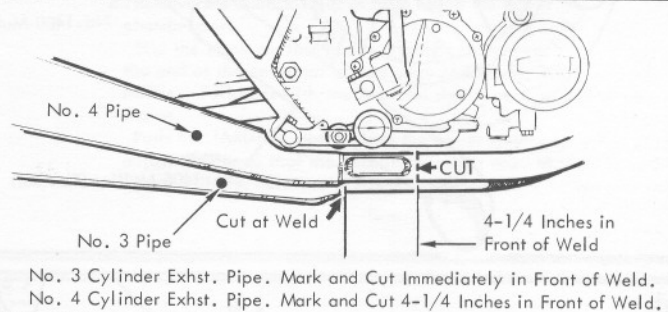

No. 3 Cylinder Exhst. Pipe. Mark and Cut Immediately in Front of Weld.
No. 4 Cylinder Exhst. Pipe. Mark and Cut 4-1/4 Inches in Front of Weld.

CB750K No's. 1750A Bell
1765 Turnout
(1977 and 1978 "K" Models)

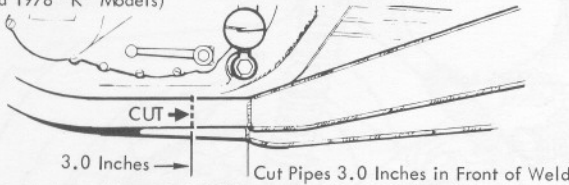

Cut Pipes 3.0 Inches in Front of Weld

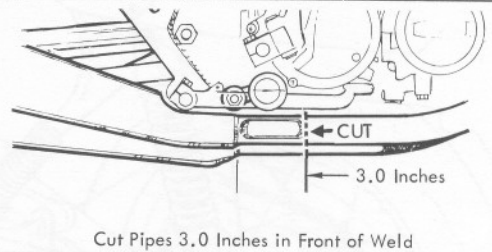

Cut Pipes 3.0 Inches in Front of Weld

CB750K No's 1770 Megaphone
1775 Turnout
(1979 and On "K" Models)

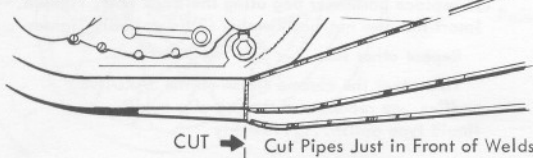

CUT → Cut Pipes Just in Front of Welds

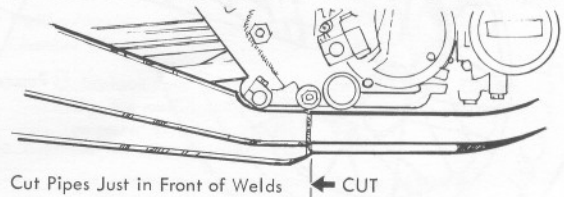

Cut Pipes Just in Front of Welds ← CUT